

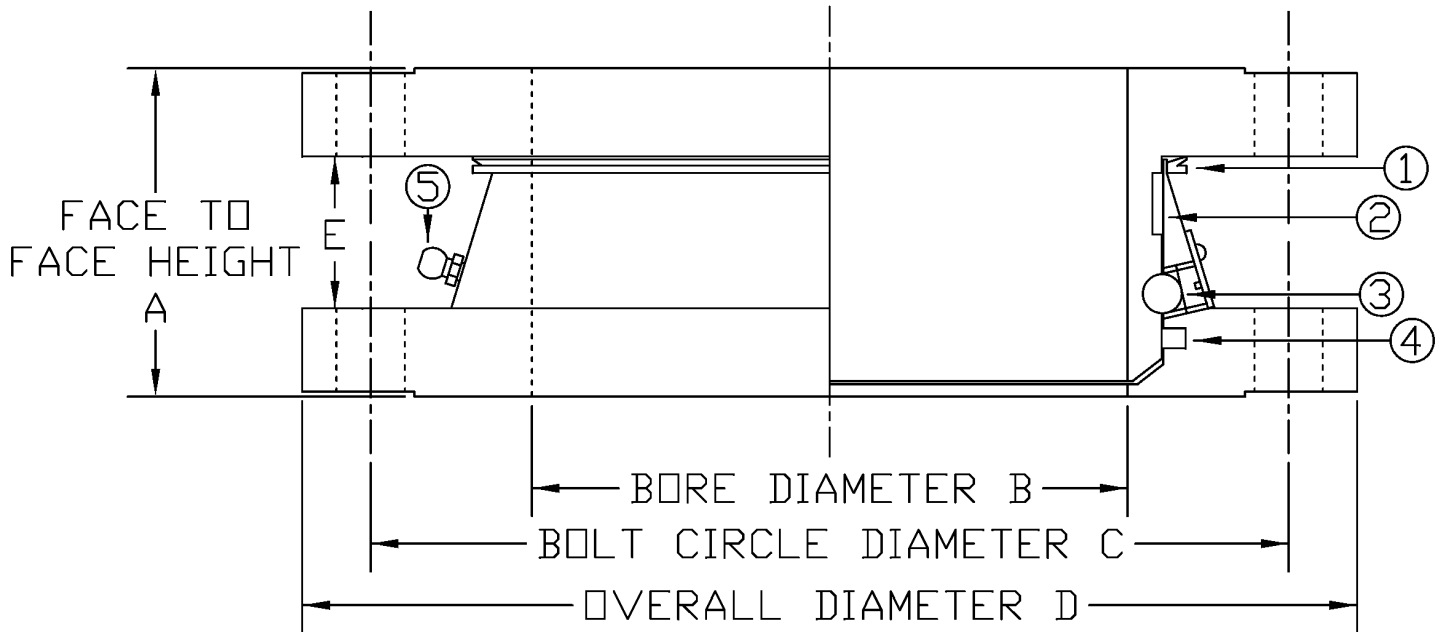

LIGHT DUTY SWIVEL JOINTS

2" To 8" ANSI 150 Flanged.



1. Dust seal, keeps the dirt out and allows grease purging to clean the bearing area.
2. Needle roller bearings, very high load capacity, keeps the main bearing and seal perfectly aligned.
3. Full compliment ball bearings, high load capacity, balls are installed through a single hole so that it is virtually impossible for the swivel to separate in service.
4. Main seal, Standard Nitrile rubber is one of the best wearing rubbers, other materials available include fluorocarbon and PTFE.
5. Regreasable, regular greasing will purge contaminates from the bearing area to give a long service life.

Nominal Size	Flange Face to Face Height, A	Bore Diameter, B	Bolt Circle Diameter, C	Number of Bolt Holes	Diameter of Bolt Hole	Overall Diameter, D	Length Between Back of Flanges, E	Rated Working Pressure, (PSI)
2"	68	49	121	4	19	152	30	150
3"	78	74	152	4	19	191	30	150
4"	82	97	191	8	19	229	34	150
5"	94	122	216	8	22	254	47	150
6"	95	146	241	8	22	279	44	150
8"	106	194	298	8	22	343	49	150

All dimensions in mm unless otherwise stated, tolerance ± 0.5

- Carbon steel and 316 Stainless steel versions available.
- Other flange sizes available on application.
- Exceptionally low height.

Please check clearance for nuts between flanges.



ROTAFLOW FV LIMITED

Tech spec: 108/030903

Rotec House, Bingswood Trading Estate, Whaley Bridge,
 High Peak, SK23 7LY. Tel: 01663 735003 Fax: 01663 735006
 E-mail: sales@rotaflow.com Web: www.rotaflow.com

