

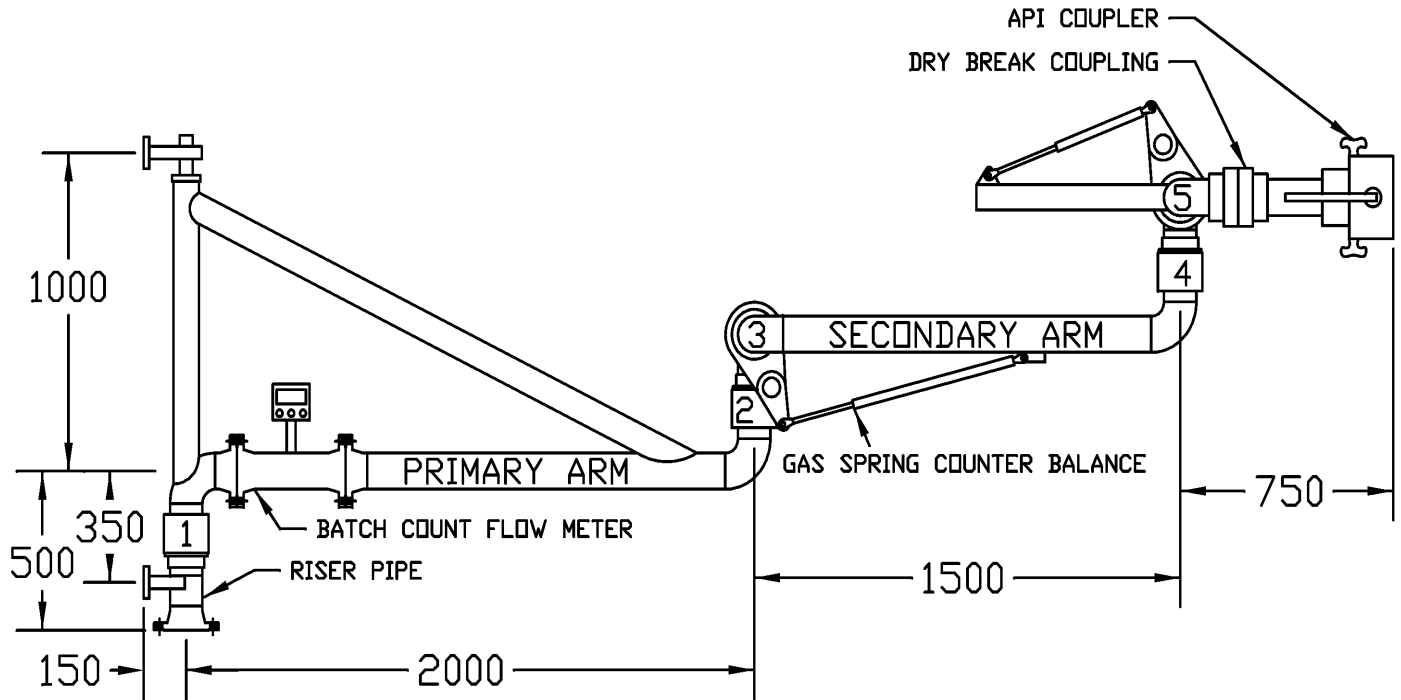

LOADING ARMS

API Bottom or Side filling with Batch Meter.



For bottom filling of road or rail tankers.

4"(DN 100) nominal bore with API quick release coupling and dry brake away coupling.

Features:

- The API coupling is self sealing so that spillage is minimised when connecting and disconnecting.
- The Dry Brake safety coupling allows controlled separation of the arm in the event that the vehicle moves away whilst the arm is connected. It is self sealing to minimise spillage.
- The Batch count flow meter can control a pump or valve to load a preset or set volume. The meter can display flow rate, accumulated totals and count down batch. Intrinsically safe.
- Carbon or Stainless Steel Construction.
- Gas spring counter balance, for a smooth dampened operation which holds the arm stationary in all positions. The gas spring arrangement is more compact and does not require extra space behind the arm for a bulky counter weight.

Choose:

- Nitrile seals for long life and low cost.
- Non-toxic nitrile for food products.
- Viton seals for oil products.
- PTFE seal for chemical compatibility.

ORDERING DETAILS			
MATERIAL	SIZE	SEAL	RISER FLANGE
CARBON STEEL	4"	NITRILE	PN16 ANSI 150
STAINLESS STEEL		NON-TOXIC NITRILE	
		VITON	
		PTFE	

All designs can be modified to suit your exact requirements.
We also supply standard, special and multiport swivel joints.

ROTAFLW FV LIMITED

Tech spec: 103/030903

Rotec House, Bingswood Trading Estate, Whaley Bridge,
High Peak, SK23 7LY. Tel: 01663 735003 Fax: 01663 735006
E-mail: sales@rotaflow.com Web: www.rotaflow.com

