

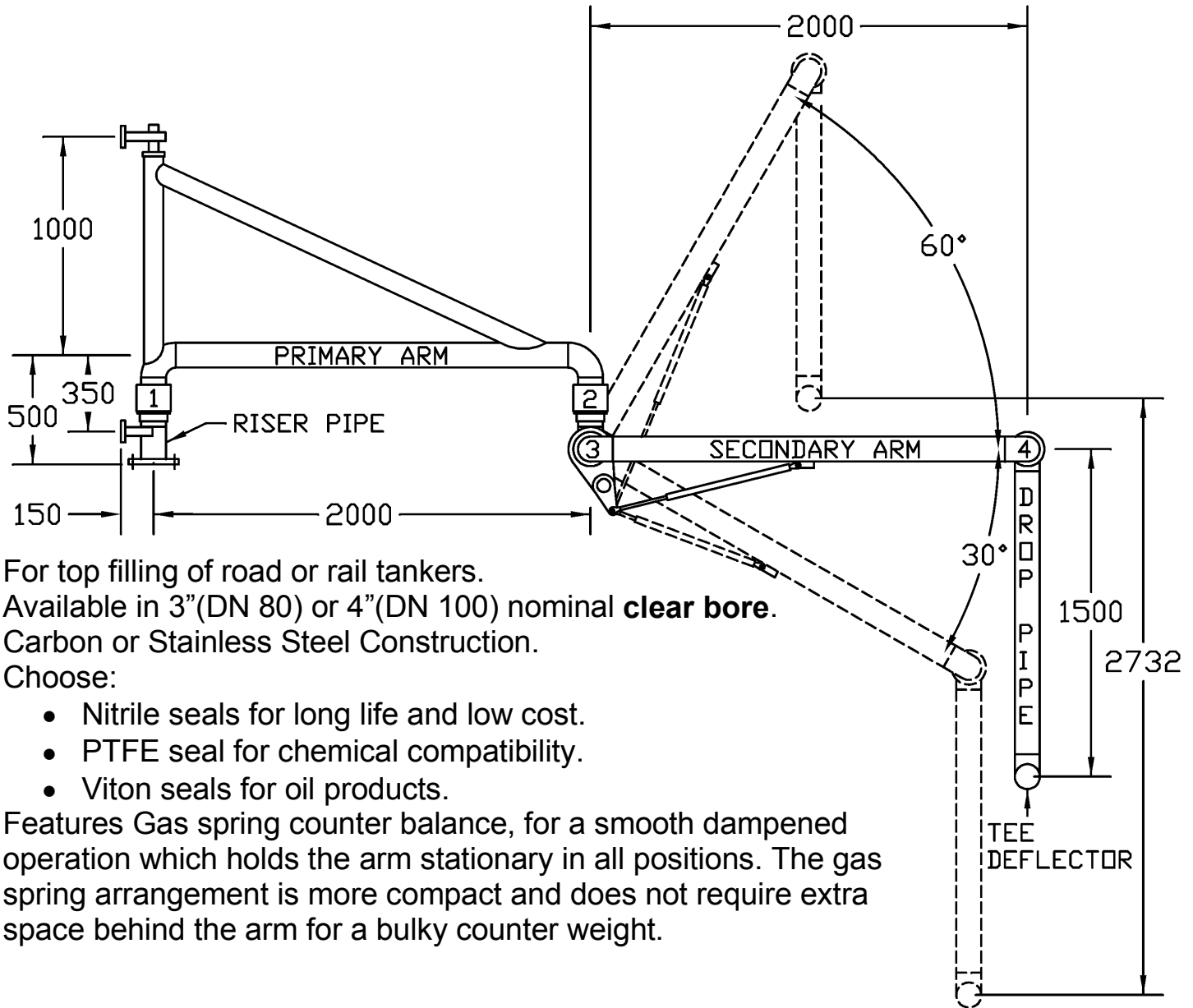

LOADING ARMS

Basic top filling.



For top filling of road or rail tankers.

Available in 3"(DN 80) or 4"(DN 100) nominal **clear bore**.

Carbon or Stainless Steel Construction.

Choose:

- Nitrile seals for long life and low cost.
- PTFE seal for chemical compatibility.
- Viton seals for oil products.

Features Gas spring counter balance, for a smooth dampened operation which holds the arm stationary in all positions. The gas spring arrangement is more compact and does not require extra space behind the arm for a bulky counter weight.

ORDERING DETAILS

MATERIAL	SIZE	SEAL	RISER FLANGE
LC4 (CARBON STEEL)	075 (3")	1 (NITRILE)	3 (PN16)
LD4 (STAINLESS STEEL)	100 (4")	4 (VITON) 5 (PTFE)	4 (ANSI 150)

All designs can be modified to suit your exact requirements.
We also supply standard, special and multiport swivel joints.

ROTAFLOW FV LIMITED

Tech spec: 100/030903

Rotec House, Bingswood Trading Estate, Whaley Bridge,
High Peak, SK23 7LY. Tel: 01663 735003 Fax: 01663 735006
E-mail: sales@rotaflow.com Web: www.rotaflow.com

