

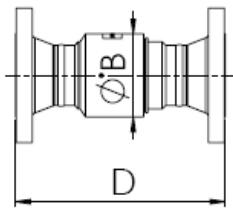

# SK SERIES SWIVEL JOINTS

NOMINAL BORE 1" TO 6"

WELD NECK FLANGED (ANSI 150lb, 300lb & 600lb)



Style: 1 (20)

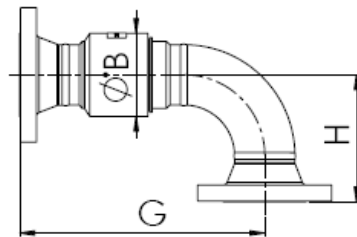

Style: 2 (30)

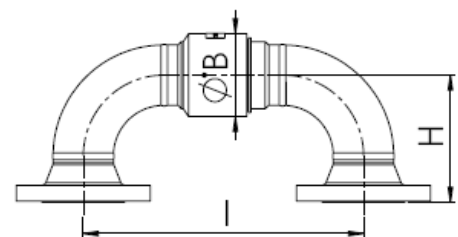

Style: 3 (40)

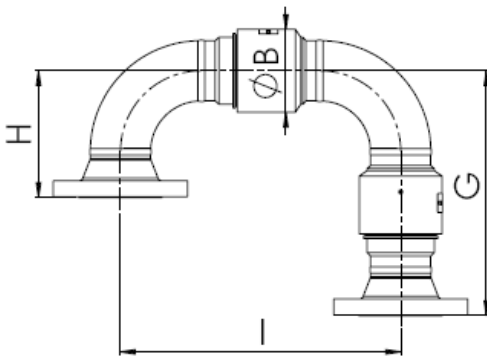

Style: 4 (50)

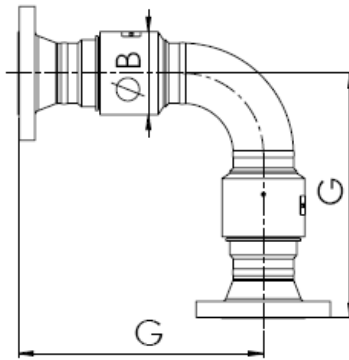

Style: 5 (60)

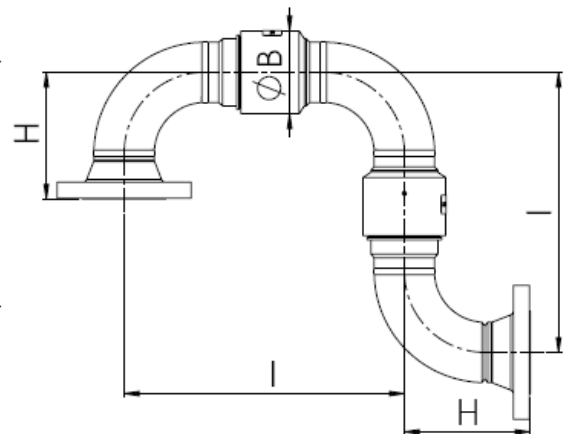

Style: 6 (70)

BORE (in.)	B Dia (mm)	I	WN FLANGED ANSI 150 lb			WN FLANGED ANSI 300 lb			WN FLANGED ANSI 600 lb			
			D	G	H	D	G	H	D	G	H	
1"	24	68	217	252	235	96	265	241	102	278	247	108
1 1/2"	38	79	265	274	270	121	288	277	128	303	284	135
2"	49	94	312	287	300	142	300	306	148	319	316	158
3"	73	121	425	335	380	186	355	390	196	374	399	205
4"	97	157	531	379	455	231	397	464	240	442	486	262
5"	122	185	607	403	505	281	423	515	291	467	537	313
6"	146	216	663	383	524	320	403	533	329	454	559	355

NOTE: Tabulated dimensions are for long radius elbows on all sizes. Other weld neck flanges or short radius elbows are available on request.

- Allowances for welding = 2mm per weld.
- The swivel bore is schedule XS (80) unless otherwise specified.
- The fittings and elbows are schedule STD (40) unless otherwise specified.

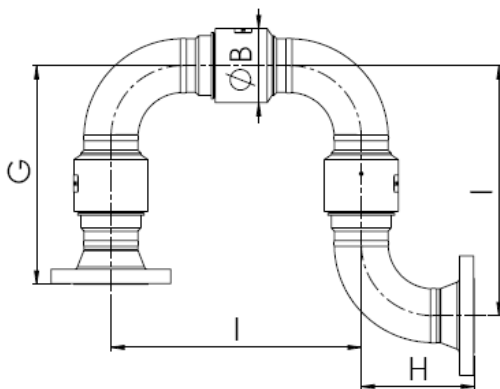

Style: 7 (80)

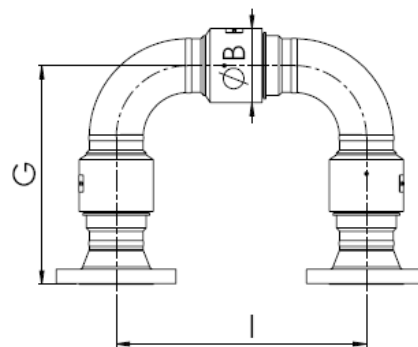

Style: 8 (10)

ROTAFLOW PROVIDE A DESIGN SERVICE

Assistance can be given on the configuration of joints for space saving in difficult areas, high pressure and larger bore designs. PTFE seals are offered as standard. Other materials including Nitrile, Fluorocarbon (Viton®), Aflas®, HNBR, EPDM are available.

Aflas is a trademark of Asahi Glass.  
Viton is a trademark of DuPont Performance Elastomers

Drawings above are not to scale and are used for graphical representation only.

Copyright © 2016 Rotaflow FV LTD

## Rotaflow FV Limited

Rotec House, Bingswood Trading Estate, Whaley Bridge, High Peak, SK23 7LY  
www.rotaflow.com tel:+44(0)1663 735003 fax:+44(0)1663 735006  
email:sales@rotaflow.com

Tech Spec:  
220/170718  
Page 1 of 1